

Instrucțiuni de montaj

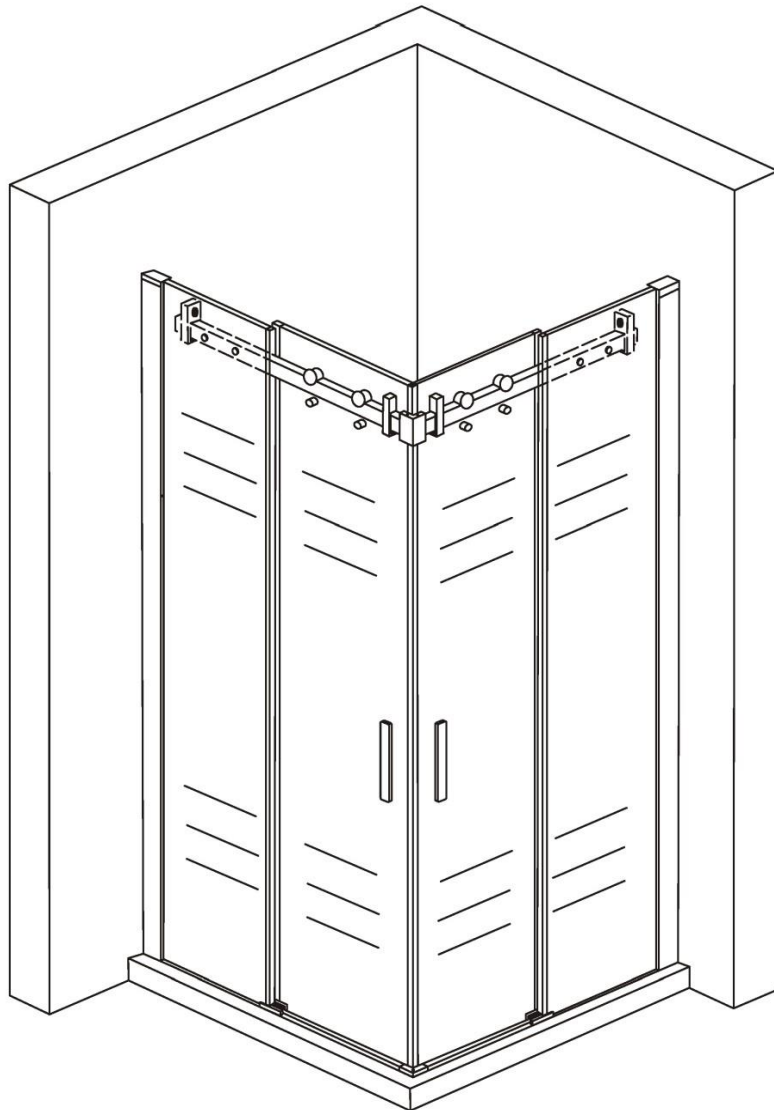

3073/3074

RoHS **CE** ISO9001:2000

Instrument necesar

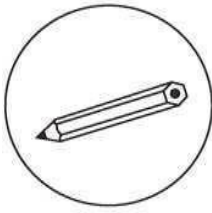

Creion

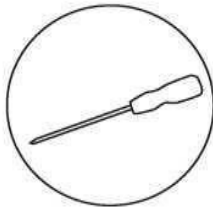

Șurubelniță

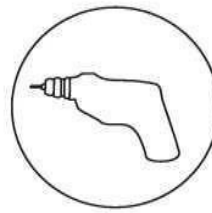

burghiu

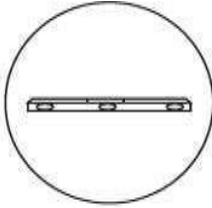

Boloboc

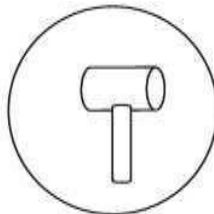

ciocan de cauciuc

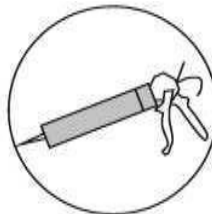

silicon

Părți

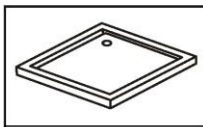

cada

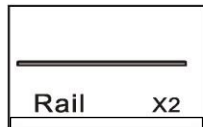

bara

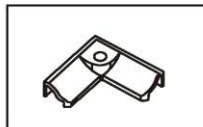

PJ-4579

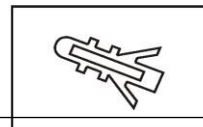

diblu

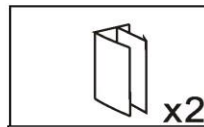

Profil perete

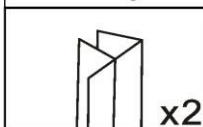

CT-8DST90

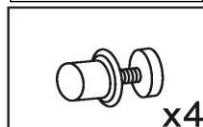

PJ-4419

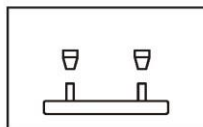

LS-1009

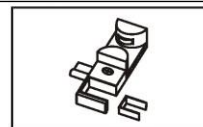

PJ-4131

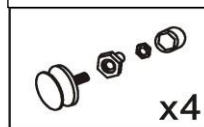

LZ-5012

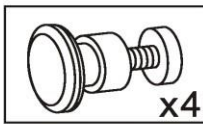

PJ-4418

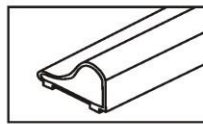

PJ-4026

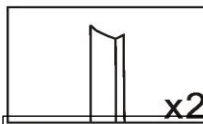

profil

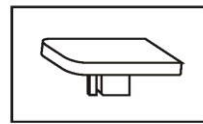

PJ-4509

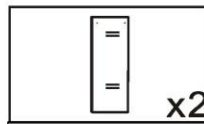

geam

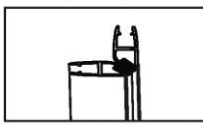

CT-8BMX90

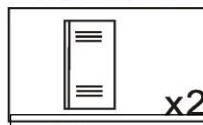

geam

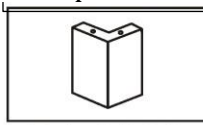

PJ-4032

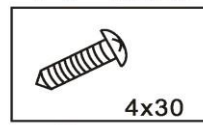

Screw
surub



Screw
surub



Cheie
hexagonala

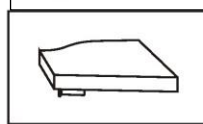

PJ-4514/
PJ-4515

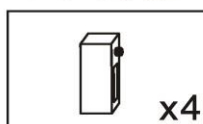

PJ-4012

Desenați liniile de asamblare, vă rugăm să rețineți instrucțiunile de asamblare

Măsurători	Baghetă profil	L1	L2
800 x 800 mm	Pre-foraj	770 mm	770 mm
900 x 900 mm	Pre-foraj	870 mm	870 mm
1000 x 1000 mm	Pre-foraj	970 mm	970 mm

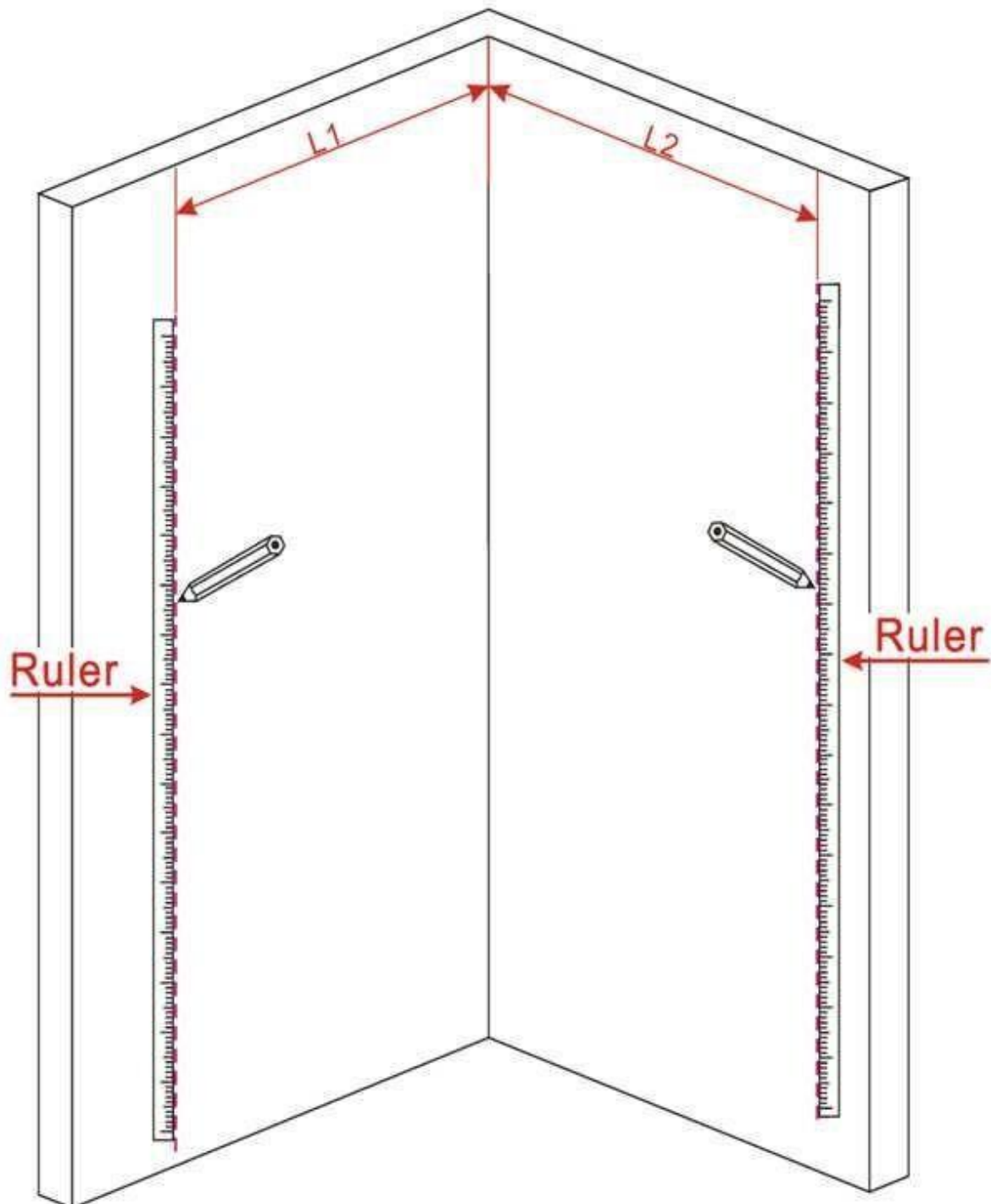

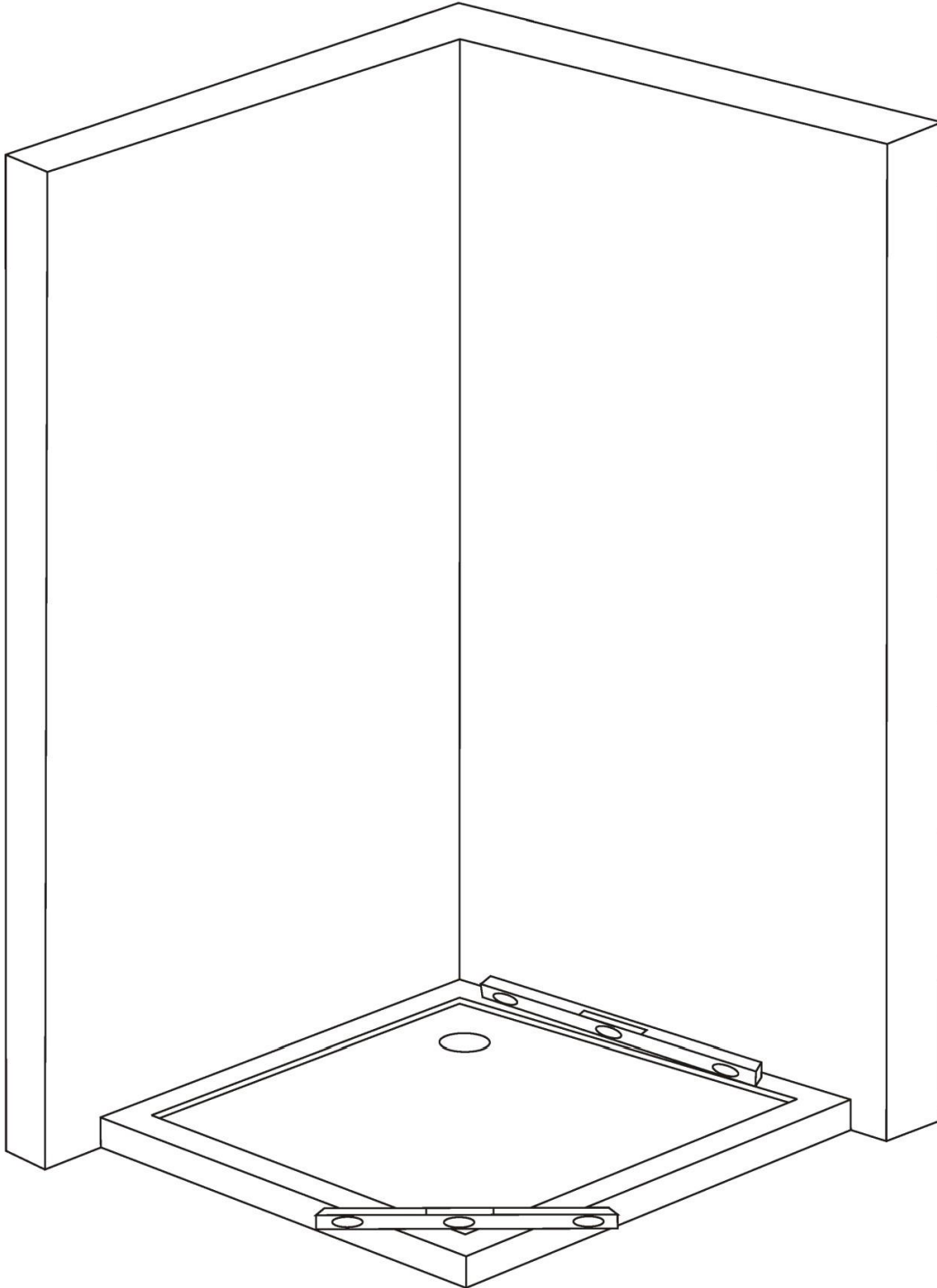
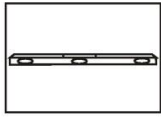
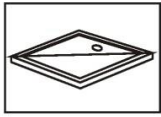

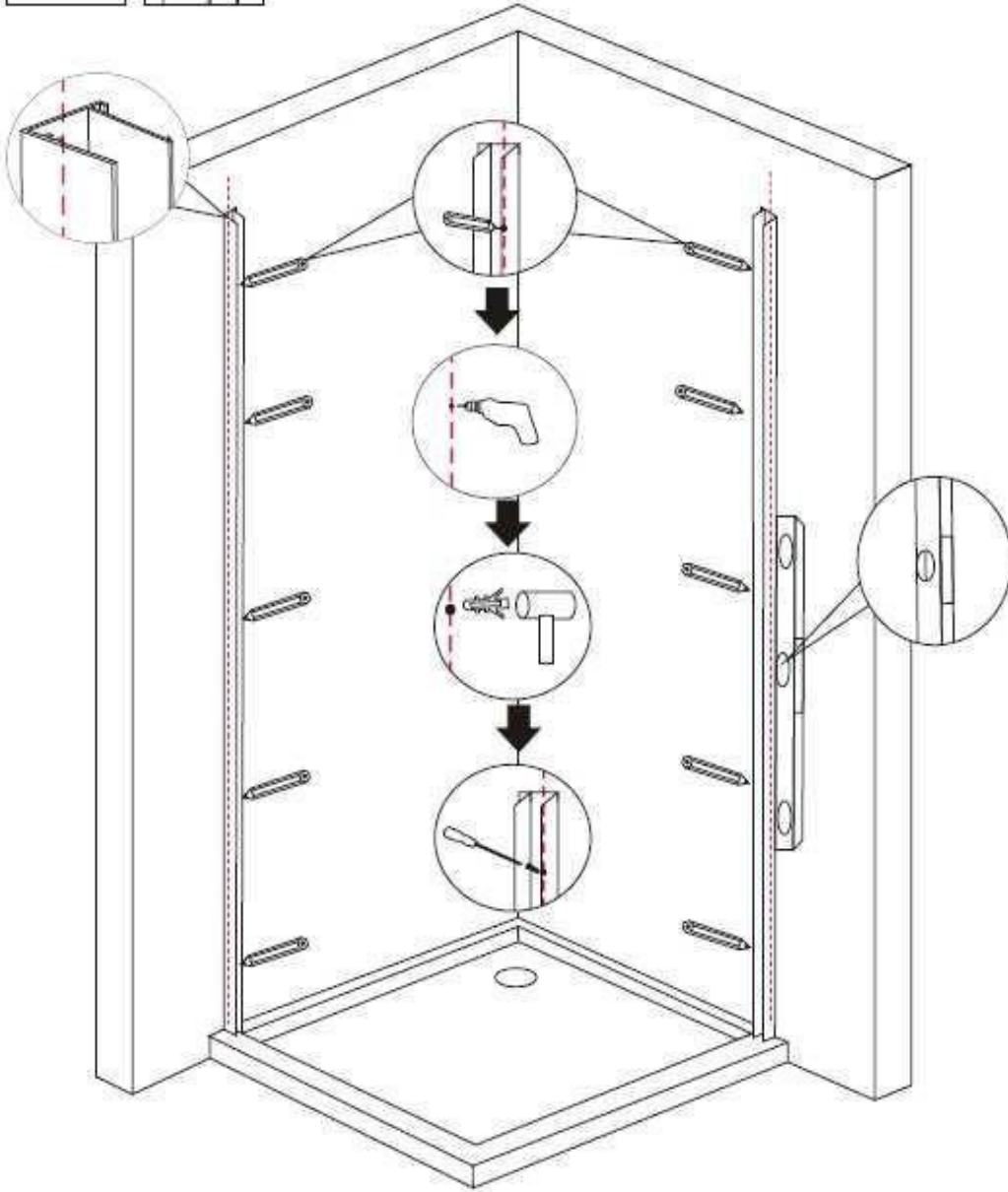
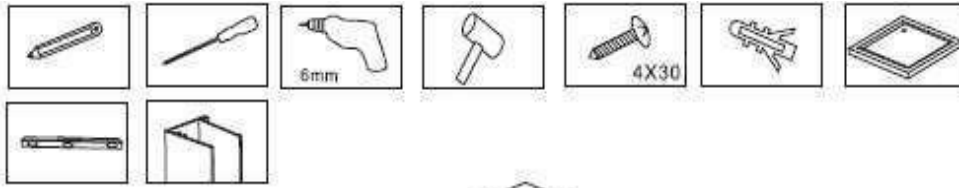

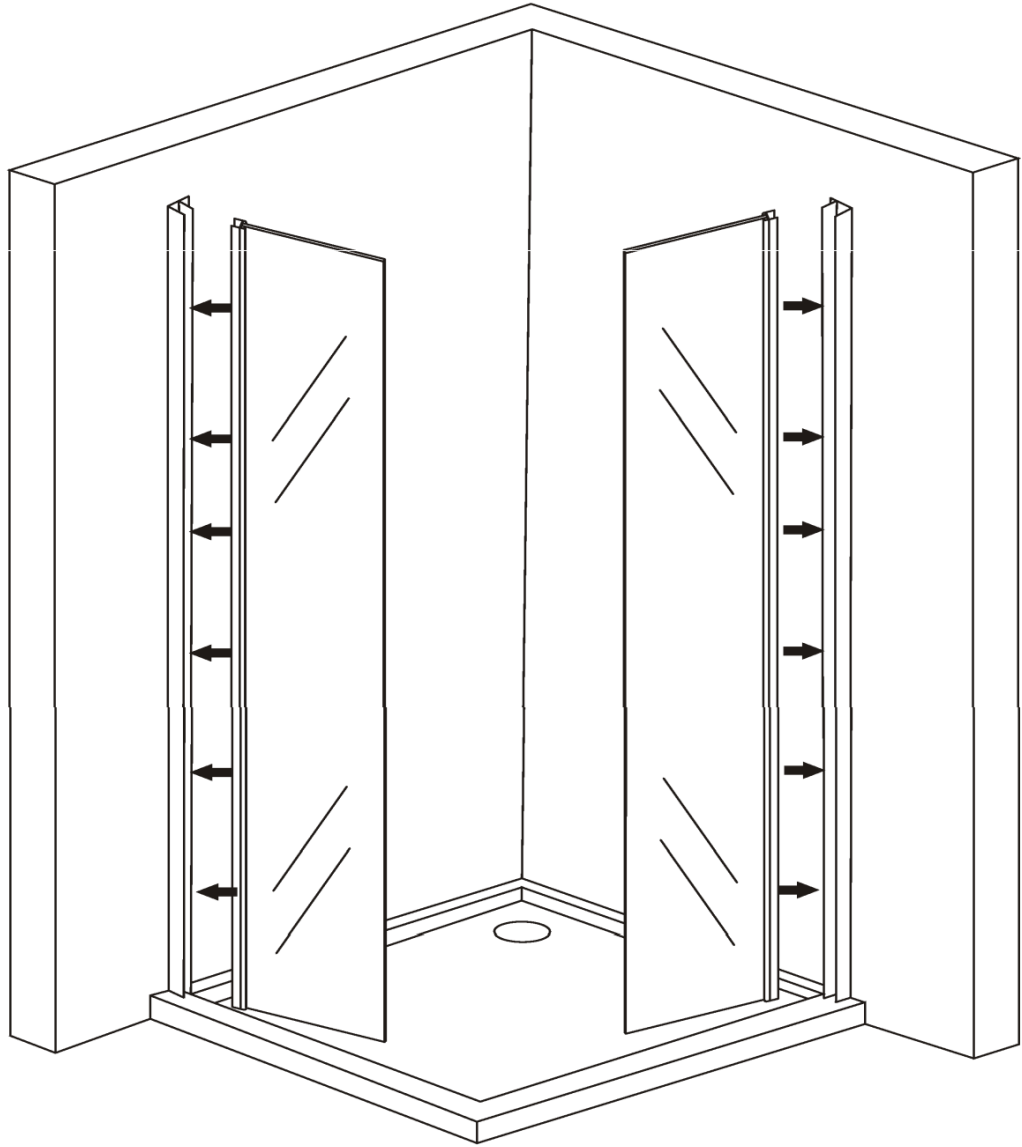
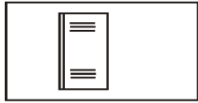

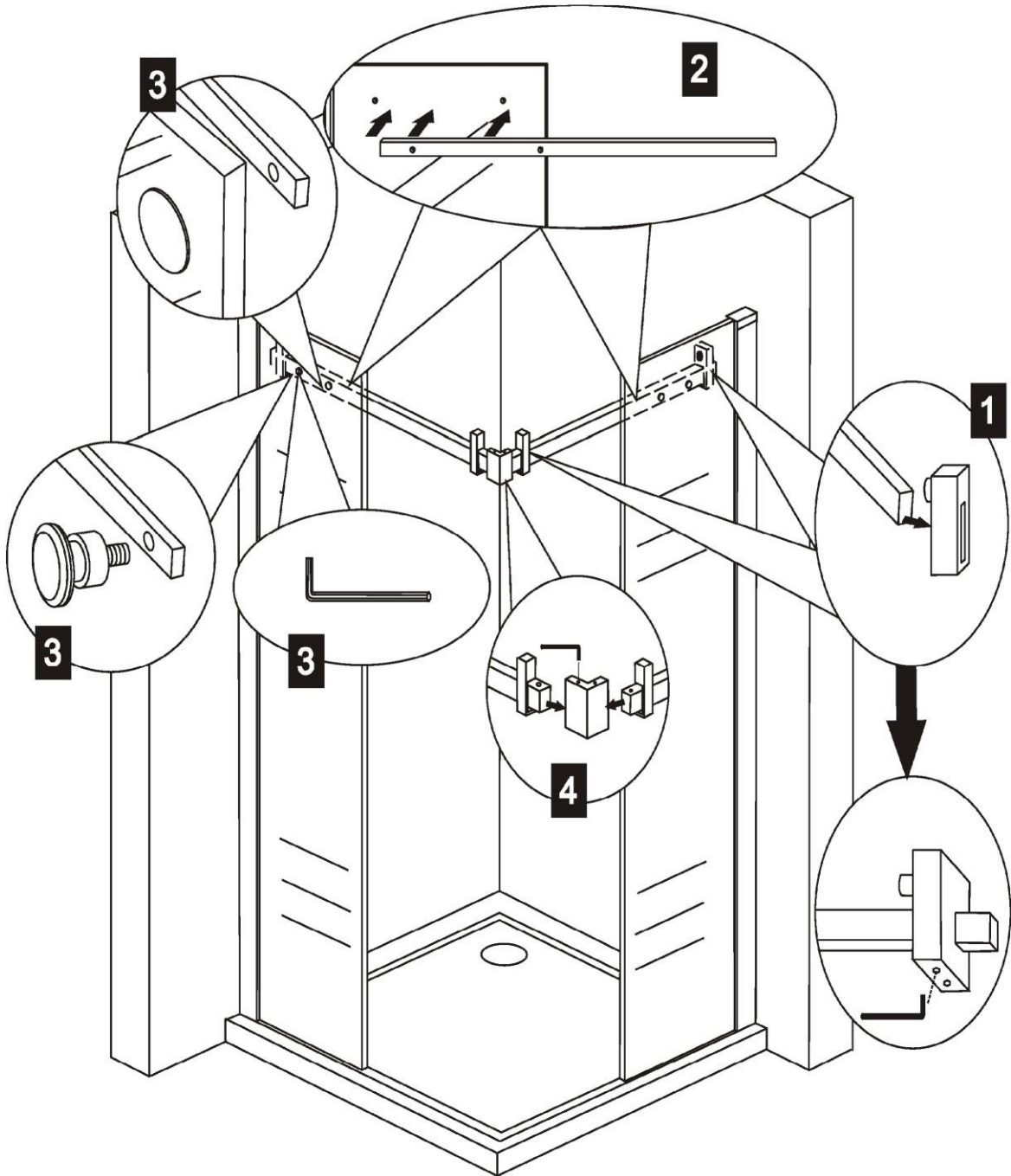
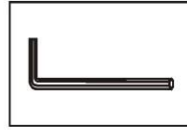
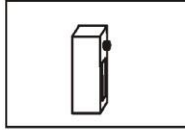
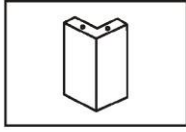
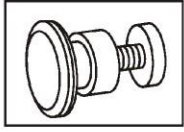

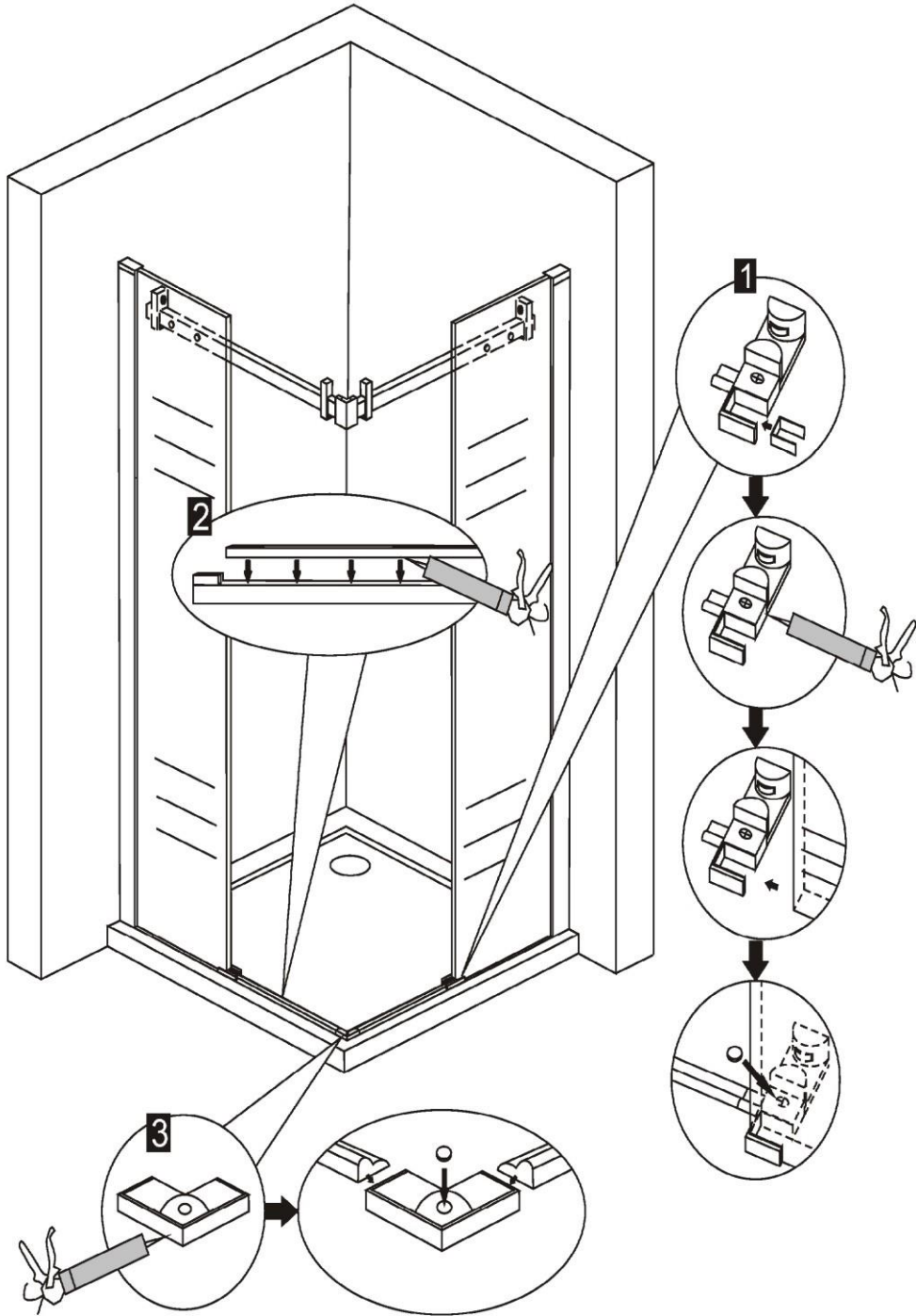
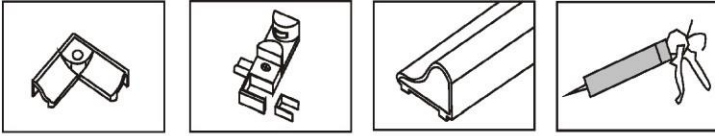

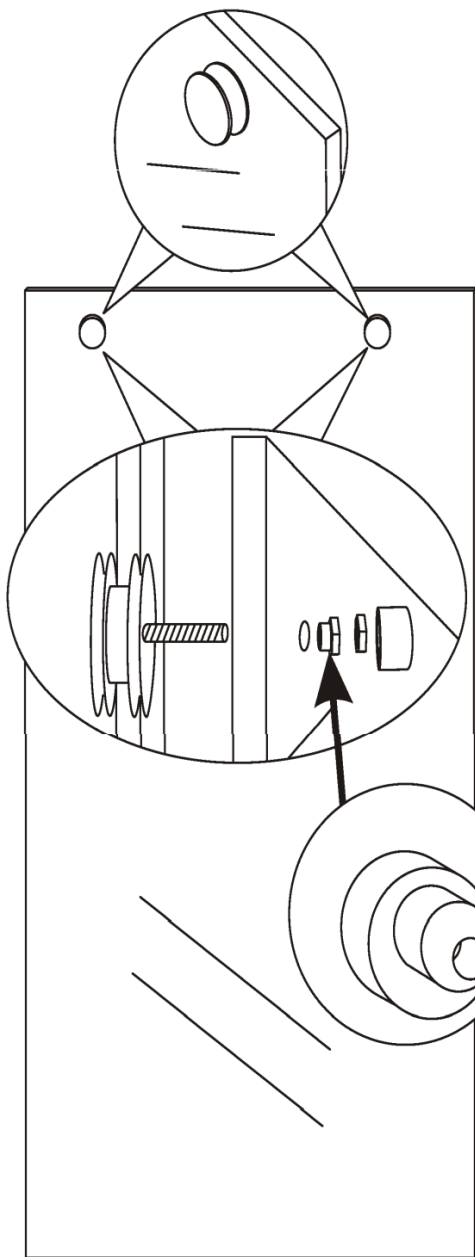
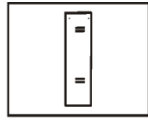
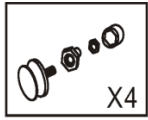

Reglați rola în consecință
1. scurtați distanța dintre sticlă și șină
2. prelungiți distanța dintre geam și șină

